

4/8-Channel, 0-10V, DIN-mount, PWM LED Dimmers for High Power RGBW Applications

DIM44NDIN v2 (RGBW); DIM84NDIN v2 (dual RGBW)

- Four or eight independent dimming channels
- 0-10V universal control
- 12V or 24V DC low voltage operation (9 – 32V range)
- Up to 5A load per channel, no minimum load requirement
- Suitable for LEDs, incandescent or halogen lamps
- Suitable for common anode LED tape/strip
- Suitable for RGBW applications
- Drives the lamp on the low (negative) side
- 240Hz high resolution PWM dimming
- Flickerless dimming of lamps and compatible LEDs
- Optional dual power supply operation

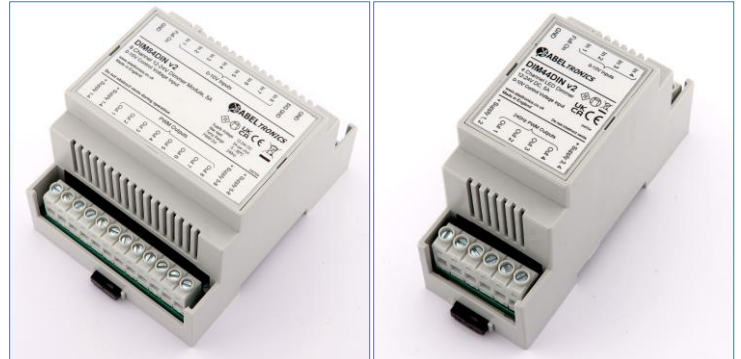

Images Representative

Overview

The DIM44NDIN v2 and DIM84NDIN v2 are self-contained multichannel DIN-mountable dimmers designed to control the brightness of low-voltage incandescent (filament), halogen or LED lamps rated up to 5A per channel. Operating from 12 or 24V DC, and offering a negative (low-side) output, the modules can be used in a wide variety of applications where DC low-voltage brightness control is desired, such as 12V or 24V automotive or marine dash-panels, low voltage architectural lighting, electronic signage, advertising backlighting, hazardous area lighting, etc. The modules are particularly suitable for driving high power RGBW LED tape or strip.

0-10V Control

Each channel of the dimmers is controlled by a universal 0-10V analogue voltage input applied to the 'In' terminals. (The common negative of the 0-10V controller should be connected to one of the 'GND' terminals of the DIM44NDIN v2 or the 'SIG GND' terminal of the DIM84NDIN v2). The control inputs are current-sink types with a maximum draw of 1mA. The inputs are designed to accept analogue 0-10V control signals from a PLC, lighting controller, Crestron™/Lutron™ controller, or similar. As the input signal is varied between 0 and 10V the respective LED or lamp changes in brightness. An input of less than 0.2V turns the output fully off, and more than 9.8V turns the output fully on.

For best performance the control input must be connected to a low impedance source of less than 100Ω. Most PLCs, Crestron™ controllers and other lighting controllers fulfil this requirement. An application note for our 0-10V single channel dimmer DIM14 shows how best to connect the control voltage input to minimise electrical noise and lighting flicker. The application note is available at www.abeltronics.co.uk/products/dim14. The control voltage input and the dimmer supply voltage are not electrically isolated from each other and share a common negative.

PWM Dimming

The units employ a very efficient PWM (pulse-width modulation) switching technique to provide excellent operation for high power loads, and the modules will control lamp brightness from 0% (fully off) to 100% (fully on) with no minimum load requirement. The PWM frequency is set at 240Hz, with >30,000 dimming steps.

The PWM output is suitable for constant-voltage (not constant-current) loads. Also, the PWM dimming technique does not change the output voltage: If using 12V LEDs, a 12V power supply will be required.

Please note that the PWM dimming technique may not be suitable for some encapsulated LED lamps containing internal driver circuitry, such as low-energy replacements for dichroic lamps. Also, the

modules are not suitable for connection to standard household lighting transformers as these supply AC and not DC voltage.

Dimming Curve

The modules feature our unique cubic-law dimming curve which allows finer control of low brightness levels and compensates for the non-linear response of the human eye. The result is an extremely smooth transition between dimming levels with no visible steps in the dimming response, and the brightness ramp-up and ramp-down is perceived by the eye to be completely linear.

Soft Start

The modules utilise a soft-start feature at power-on, where the lamp brightness increases gradually to the preset brightness setting. This preserves the life of incandescent lamps as the filament is not 'slammed' on. The soft-start takes less than half a second.

Full Brightness Input

The modules feature a 'Full-On' input. When this input is connected to a positive voltage above about 4V all channels are brought up to full brightness immediately, irrespective of the voltage present at any of the 'In' terminals. This is useful for emergency lighting applications where, in the event of a fire or other alarm trigger, all dimming needs to be overridden and all connected lamps need to be fully on. (Please note, this is not a substitute for a suitably approved, redundant, emergency lighting system). The terminal should be left unconnected if this feature is not required.

Power

The power supply to the unit typically comes from a suitably rated low-voltage DC supply in the range 9 – 32V which must be fused at the total load current or less to protect the module.

If using switched-mode power supplies, we recommend overrating the power supply by 1.5x. For example, if the total load of all the channels powered by the power supply is 200W, use a 300W power supply. The dimmer connection diagrams are shown on the following pages. Note the multiple cables leading from each GND terminal to fuse on the

power supply negative output. This is necessary to ensure the dimmers can control the load with maximum efficiency.

The dimmers are suitable for direct connection to automotive or marine systems of 12V or 24V nominal. The configuration is similar to the diagrams below, except the 12V/24V power supply is substituted for the vehicle's, or vessel's, battery.

Dual Power Supplies

The DIM84NDIN v2 has split internal construction where two power supplies can be used, each to power half the dimmer. The left-hand +Supply terminal powers channels 1-4 and the right-hand +Supply terminal powers channels 5-8. (This is in contrast to the original version of the DIM84NDIN where both +Supply terminals are internally connected together).

Since the dimmers are capable of significant load currents, this flexibility allows two smaller power supplies to be used in the place of one much larger unit.

Each half of the DIM84NDIN v2 can run at a different supply voltage if desired. For example, channels 1-4 can operate from 12V, and channels 5-8 can operate from 24V.

In addition, each half of the dimmers can be powered on or off independently. For example, in an automotive/marine application, channels 1-4 could be connected to a permanent supply, whereas channels 5-8 could be ignition switched.

Only the DIM84NDIN v2 has split internal construction. DIM44NDIN v2 must be used with a single power supply.

Fault Protection

The dimmers feature rugged internal overcurrent and over-temperature protection and are fully protected against intermittent output short-circuits, over-temperature, reverse polarity, and input over/under voltage. If the units detect a short-circuit load, the output of the respective channel will switch off for 30 seconds before trying again.

The overcurrent detection response has been specifically designed to allow for the high inrush current of most incandescent lamps, but

certain large lamps may cause false triggering of the protection. It is recommended that the load be de-rated under these circumstances.

The units also feature two levels of thermal protection. If the internal channel temperature rises above approximately 80°C the unit will switch off that channel for 30 seconds. If the internal temperature continues to rise above 125°C, the internal thermal fuse will permanently trip, the faulty channel will be permanently deactivated and the dimmer will need to be replaced.

Mounting and Connection Guidelines

The dimmer is packaged in a vented DIN-mount enclosure and will run warm in operation when controlling loads above 3A per channel. It is important therefore to mount the dimmers in a suitably ventilated enclosure, ensuring the module's vent holes are unobstructed during use. The unit should be mounted in a cool location, away from external sources of heat. The unit is not water resistant and should be mounted away from sources of moisture.

Connection terminals are high quality rising-clamp terminal blocks capable of receiving up to 4mm² cable. The connectors are spaced 5mm pitch along opposite sides of the enclosure. To maximise the potential of the dimmers, cable rated at currents exceeding the lamp load by 1.5 times should be used to connect the modules, and the use of a bootlace ferrule at each terminal is strongly recommended.

DIM84NDIN v2 Changes Summary

The DIM84NDIN v2 is an upgraded version of the DIM84NDIN we have sold for many years. The differences are as follows:

- Split power supply operation – the DIM84NDIN v2 can be powered from two independent power supplies
- PWM Synchronisation – each channel's PWM output is synchronised to each other whereas on the original DIM84NDIN they were completely independent.
- 'SIG GND' connection – one of the 'Full-On' terminals on the original version of the DIM84NDIN has been repurposed as a 0-10V ground connection on the DIM84NDIN v2 for simpler wiring configuration.

DIM44NDIN v2 Connection Drawings

4 Channels, Single Power Supply

Shown below is the connection diagram for the DIM44NDIN v2 using a single power supply for all four channels.

Please note the GND output from the 0-10V controller, PLC etc is connected to the dimmer's GND terminal, which in turn is connected to the power supply negative.

The fuse shown in the positive output of the power supply should be rated at the total load of the dimmer.

[Image to follow]

DIM84NDIN v2 Connection Drawings

8 Channels, Single Power Supply

Shown below is the connection diagram for the DIM84NDIN v2 using a single power supply for all eight channels.

Please note the GND output from the 0-10V controller, PLC etc is connected to the dimmer's 'SIG GND' terminal. This terminal is internally connected to the dimmer's GND terminals.

The fuse shown in the positive output of the power supply should be rated at the total load of the dimmer.

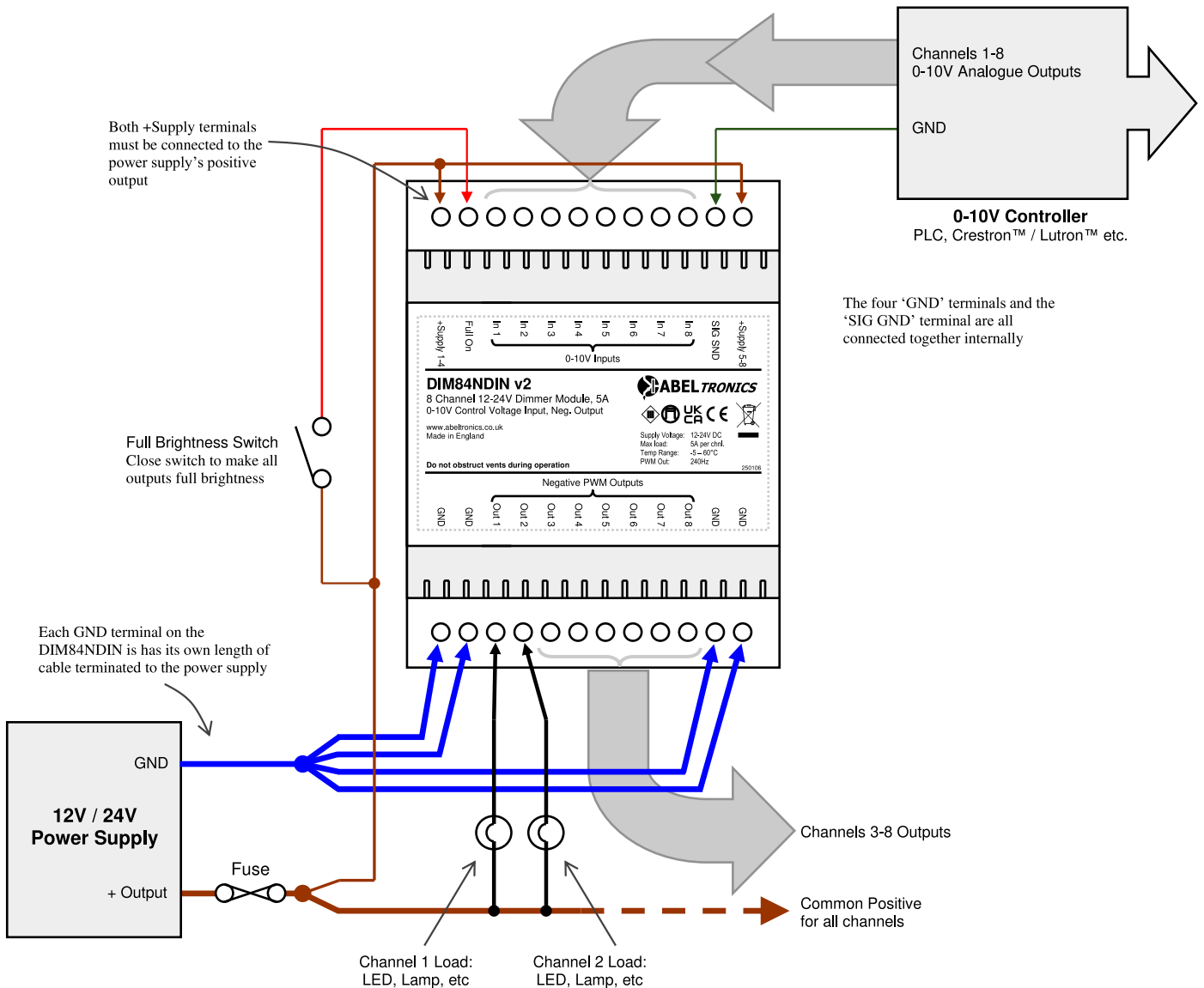

8 Channels, Dual Power Supplies

Shown below is the connection diagram for the DIM84NDIN v2 using two power supplies. The total load is therefore split across **both** power supplies.

Please note the GND output from the 0-10V controller, PLC etc is connected to the dimmer's 'SIG GND' terminal. This terminal is internally connected to the dimmer's GND terminals. The negatives from both power supplies are connected together.

The fuse shown in the positive output of each power supply should be rated at the total load of the respective half of the dimmer.

The full brightness switch is shown connected to the left-hand power supply, but it could be connected to the right-hand power supply instead.

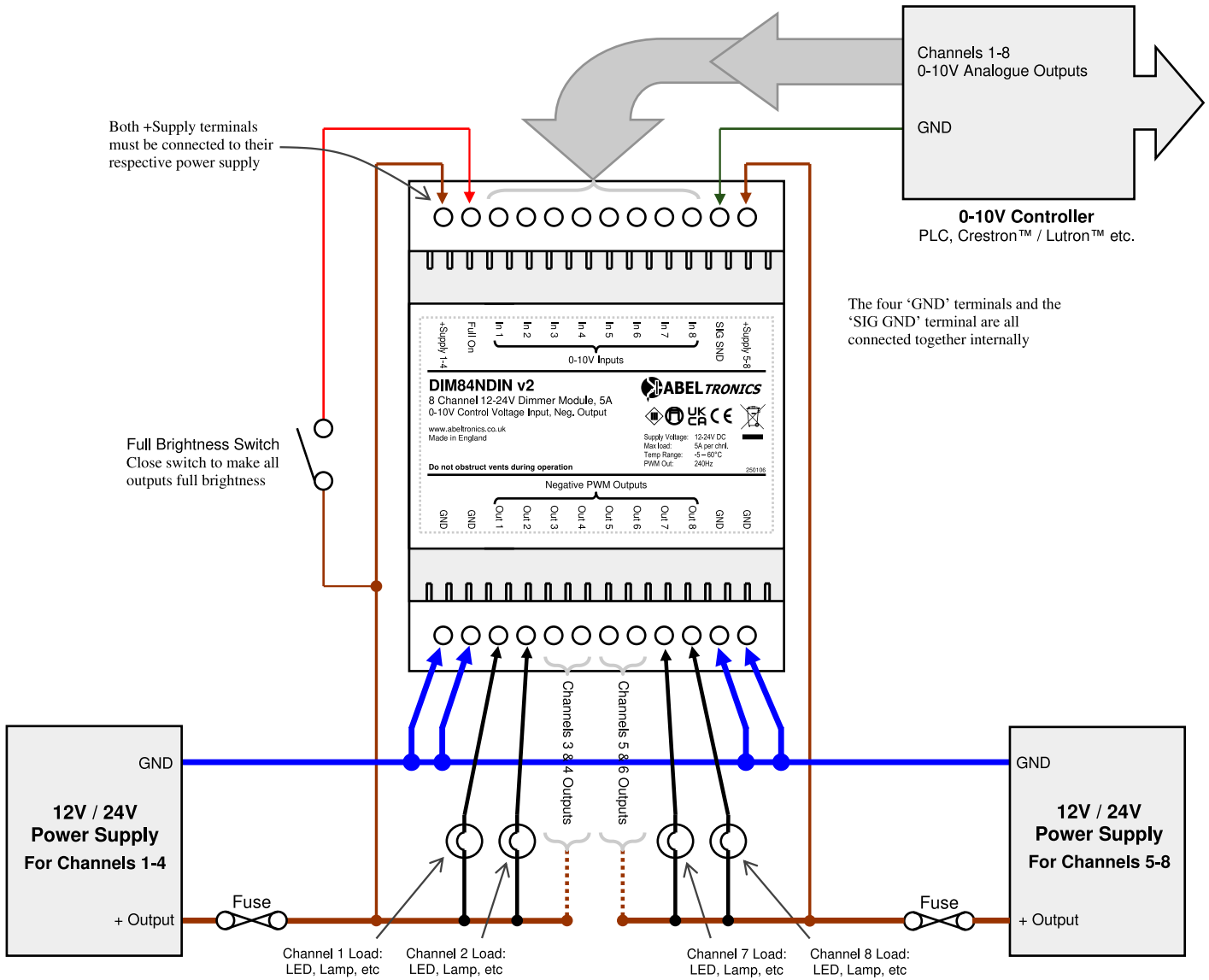

Physical

The units are each supplied in a vented enclosure designed to be mounted to standard 35mm DIN-Rail as per EN 60715. DIM44NDIN v2 is supplied in a 2-unit wide enclosure; DIM84NDIN v2 is supplied in a 4-unit wide enclosure.

Do not obstruct the vents during operation.

The unit can also be mounted to a flat surface by extending the DIN mounting clips, as shown below, to reveal screw holes.

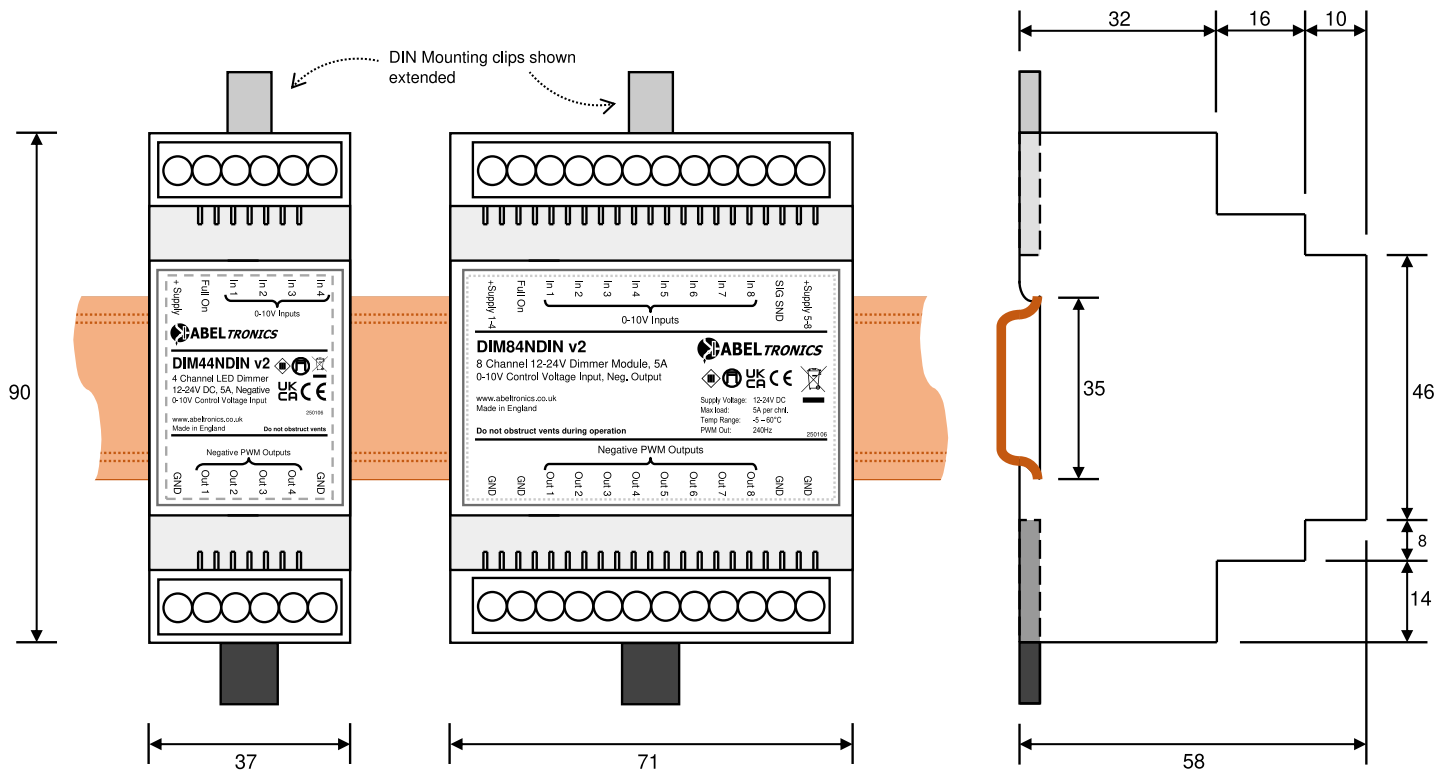

All dimensions in mm. ± 1mm

Specifications

Parameter	Value	Comments
General		
Nominal Supply Voltage Range	12 – 24V DC (9 – 32V DC Operational Range)	
Peak Supply Voltage Range	5.5 – 40V DC	Operation not guaranteed
Quiescent Current, max	40mA	at maximum operating voltage
Maximum Output Current	5A per channel	at <30°C ambient temperature
Maximum Load Power	60W at 12V supply, 120W at 24V supply, per channel	at <30°C ambient temperature
Peak Output Current	30A per channel	<3sec at nominal operating voltage
Control Input Type	0-10V Analogue Voltage	Independent control for all channels
Control Input Impedance	10 kΩ for each 0-10V input >1 kΩ for 'Full-On' input	Impedance of all control inputs
Efficiency	> 97 %	
PWM Switching Frequency	240 Hz ±3%; 0% – 100% Duty Cycle	
PWM Temporal Resolution	< 200ns	
Physical		
Terminal Cable Acceptance	0.2 – 4.0mm ² (30 – 12AWG)	Rising Clamp Terminal Block
Terminal Torque	0.5Nm	
Enclosure, DIM44NDIN v2	2-Unit DIN-Mount Polycarbonate, UL94-V0	Fits 35mm DIN Rail to EN 60715
Enclosure, DIM84NDIN v2	4-Unit DIN-Mount Polycarbonate, UL94-V0	
Environmental		
Protection Index	IP20	
Ambient Operational Temperature Range	–40 – 70°C (–40 – 160°F)	Derate loads linearly above 40°C (104°F)
Maximum Humidity	10 – 90%RH non-condensing	
RoHS and REACH Compliant	Yes	